



CONVEYOR COMPONENTS COMPANY

130 Seltzer Road, PO Box 167 • Croswell, MI 48422 USA
PHONE: (810) 679-4211 • TOLL FREE (800) 233-3233 • FAX: (810) 679-4510
Email: info@conveyorcomponents.com • <http://www.conveyorcomponents.com>

MODEL MSD MOTION CONTROL INSTALLATION AND OPERATION

The Model MSD is both a motion-sensing control and a tachometer. It has a separate rugged sensor enclosed in a heavy-duty cast aluminum (or iron) housing. Electronics are contained in a separate remote control unit away from dirt, vibration, and temperature fluctuations.

The MSD is a dual speed control with two set points permitting it to indicate two under-speed points, two over-speed points, or one each under-speed and over-speed point. At the same time, the control unit displays the actual shaft RPM on the digital readout.

Operation:

A precision metal disc with slots on its periphery is used in the sensor to generate electronic pulses as the disc rotates past an infra-red light source. These pulses are transmitted to the electronics in the control unit where the signal is analyzed and the relays are activated or deactivated at preset signal speeds. The electronic components of the control unit are designed to permit two signal set points. Field adjustment of the two signal set points is easily accomplished by a series of digital switches on the control panel.

Technical Information:

MSD-1 Sensor:

Input:	12 VDC from the control unit
Output:	12 VDC square wave to control unit
Operating Temperature Range:	-50°F to +150°F
Maximum Speed Limit:	1000 RPM
Shaft Load:	125 lbs. radial, 100 lbs. end thrust
Rotation:	Clockwise or Counter-clockwise
Drive Torque:	1 inch-pound
Shaft:	5/8" dia. x 1 1/4" long stainless steel
Enclosure:	NEMA 4 and NEMA 7, 9 cast aluminum or optional cast iron
Bearings:	Permanently lubricated and sealed for life ball bearings

MSD-2 Control Unit:

Power Input:	120 or 240 VAC, 50/60 Hz, 50 Watts Optional 240 VAC, 50 Watts Optional 24 V AC or DC, 50 Watts
Signal Input:	12 VDC square wave from sensor
Output:	2 sets DPDT rated 10 amps resistive at 125/250 VAC; 10 amps resistive at 30 VDC and 1/4 HP at 125 VAC, 60 Hz.
Operating Temperature Range:	-30°F to +140°F
Reading Accuracy:	±1 RPM
Operating Range:	0-1000 RPM
Signal Speed Range:	0-1000 RPM
Alarm Set Accuracy:	±1 RPM
Enclosure:	NEMA 1 panel mount or NEMA 12 and 4 J.I.C. surface mount

Installation and Wiring:

Mount the MSD-1 sensor in any position on a smooth, flat surface using ¼” mounting bolts and lock washers. If vibration is extreme, dowel two mounting holes and use bolts in the others. The sensor shaft must be in line or parallel with the drive shaft.

For conduit installation, use only hubs of suitable sizes that are UL/CSA approved for WATERTIGHT use. Install per the hub manufacturer’s instructions. Be sure the location selected will provide adequate wire bending space.

Use two conductor shielded cable (such as our MSD-14 or Belden 8760) to connect the MSD-2 control unit with the MSD-1 sensor. A maximum of 500 ft can be used.

The control unit contains two DPDT relays and corresponding output contacts. Output relays energize under normal operation and de-energize in the event of alarm or power failure.

Figure 1: Relay Logic

Note: relays are labeled in their non-alarmed state on the control unit.









Non-Alarm State	 N.O. 2
	 C. 2
Relay Energized	 N.O. 1
	 C. 1
Normal Operation	 N.O. 2
	 C. 2
Relay Not Energized (De-energized)	 N.O. 1
	 C. 1
	 N.C. 1

Figure 2: Setpoints



Factory Assistance:

If assistance is needed to locate difficulties with a unit or you would like information about alternate control devices, please call the factory at 1-800-233-3233 or via e-mail at info@conveyorcomponents.com.

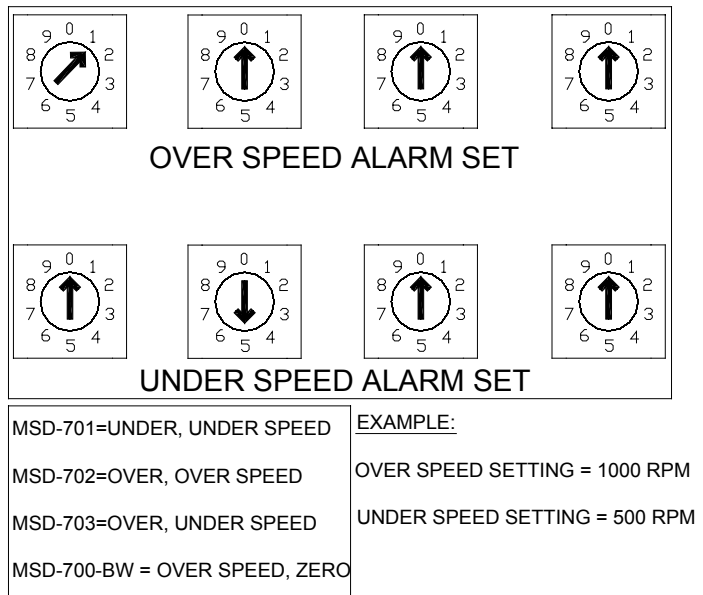
To help solve a problem quickly, please have as much of the following information as possible when you make your call:

- Model Number
- Date Purchased
- Brief Application Information
- Brief Description of the Problem.

EQUIPMENT SHIPPED BACK TO THE FACTORY WITHOUT PROPER AUTHORIZATION WILL BE REFUSED AND RETURNED AT THE SHIPPER’S EXPENSE.

Model MSD Troubleshooting Tips

PROBLEM:

Display is blank.

SOLUTION:

- a. Verify input power to controller.
- b. Verify correct connections to sensor. Interchanging connections can short the power supply, which will shut down automatically.

PROBLEM:

Display reads "0" rpm.

SOLUTION:

- a. Using an old style sensor with a newer version controller. Replace sensor with "new" style version.
- b. Incorrect connections to sensor. Verify pin 1 to 1, 2 to 2, 3 to 3. Verify pin 3 is shield on both ends.

PROBLEM:

Relays do not trip when set point is reached.

SOLUTION:

- a. Set the digital rotary switches with the appropriate trip speed (thousandths, hundredths, tenths, ones).
- b. The over speed set point **MUST** be set higher than the under speed set point, even if unused.
- c. Verify that the appropriate relay is being used.
- d. Verify the relay wiring, the relays are labeled in their non-alarmed state.
- e. The relays are dry, unpowered relays. Verify that the COM is sourced with appropriate voltage.

PROBLEM:

RPM display is erratic or inconsistent.

SOLUTION:

- a. Verify that Belden 8760 or similar shielded cable is being used between sensor and controller.
- b. Verify that the sensor cable is 500 feet or less.
- c. Verify that the sensor cable is enclosed in a metal conduit with out any power carrying cabling.
- d. Verify the controller is not mounted near any Variable Frequency Drives.

PROBLEM:

RPM display does not match the actual conveyor speed (in RPM).

SOLUTION:

Adjust RPM calibration pot located on the front of the display board near the last 7-segment display.
Note: Model MSD-700BW should read ½ actual sensor speed.

Figure 2: Sensor dimensions

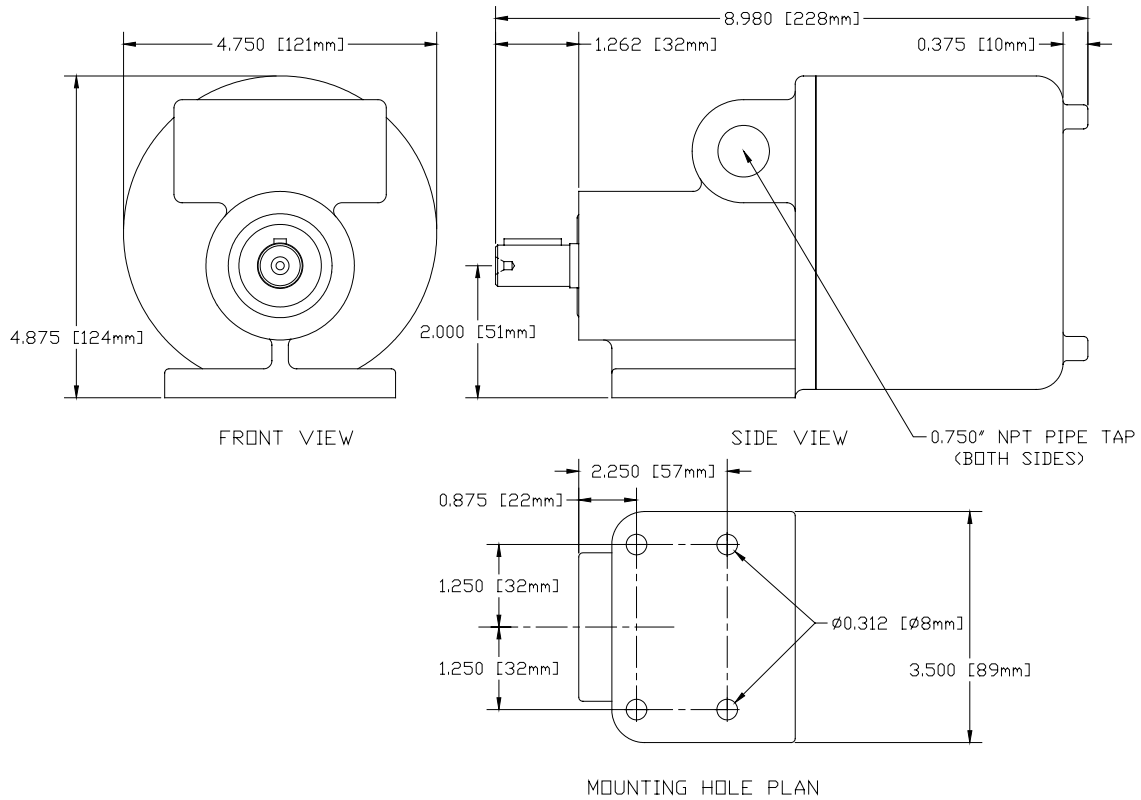

Figure 3: Panel mount control dimensions

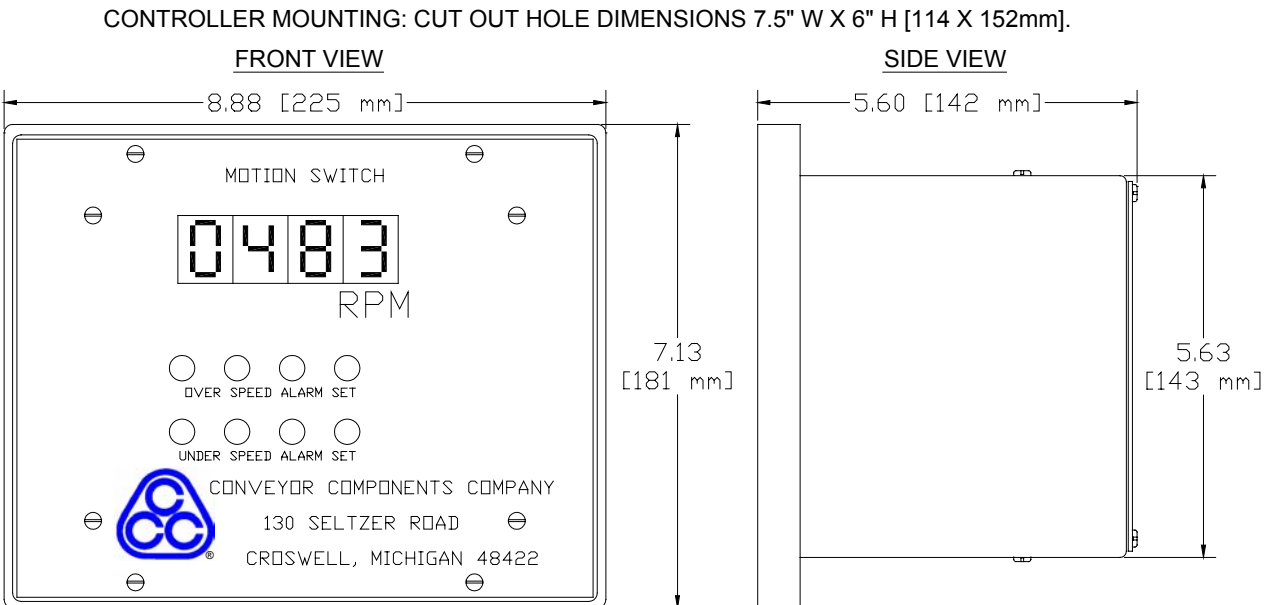

Figure 4: Chassis mount control dimensions

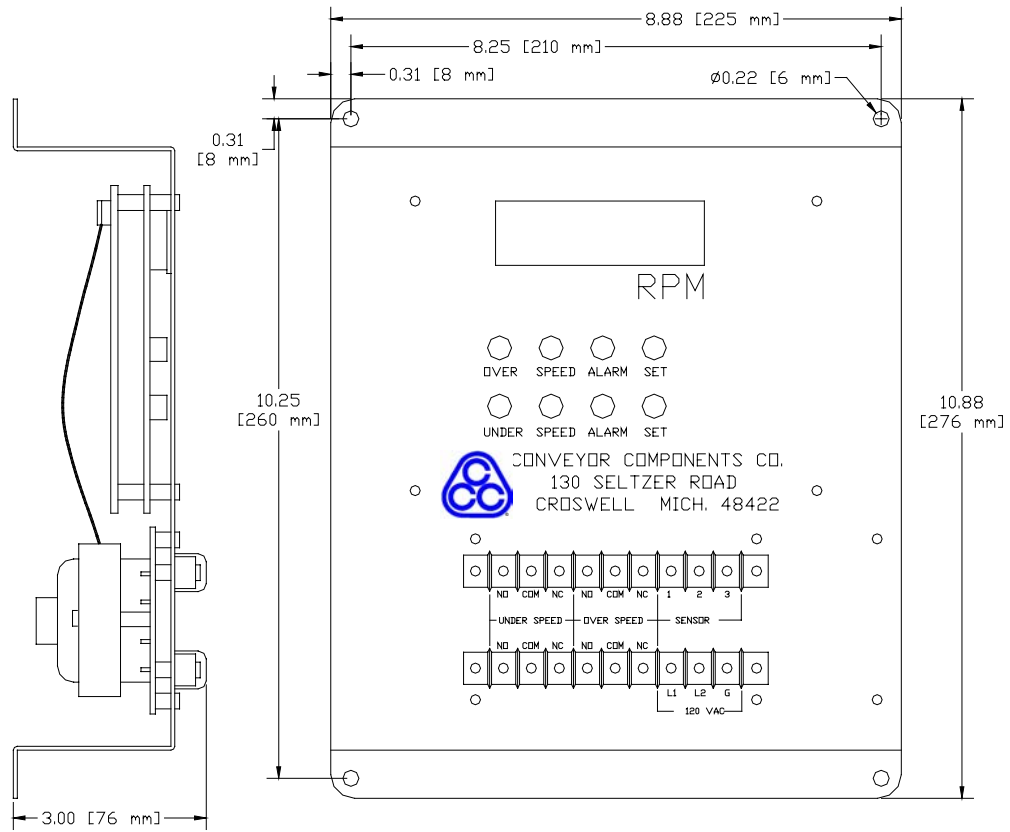

Figure 5: Sensor and control wiring

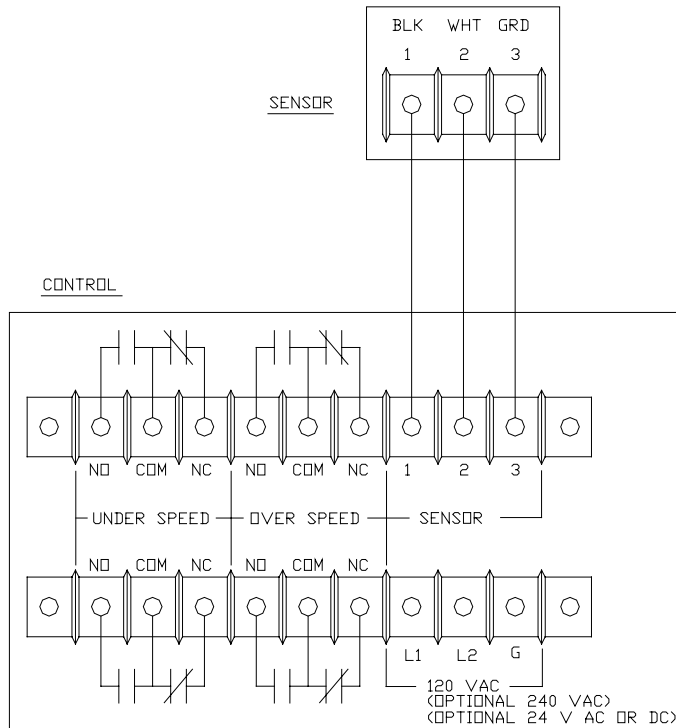

Figure 6: Use of flexible coupling

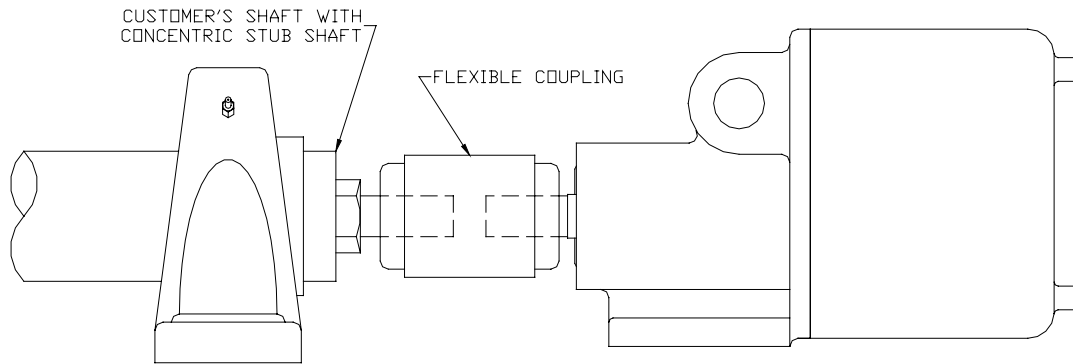

Figure 7: Offset mount using spur gears

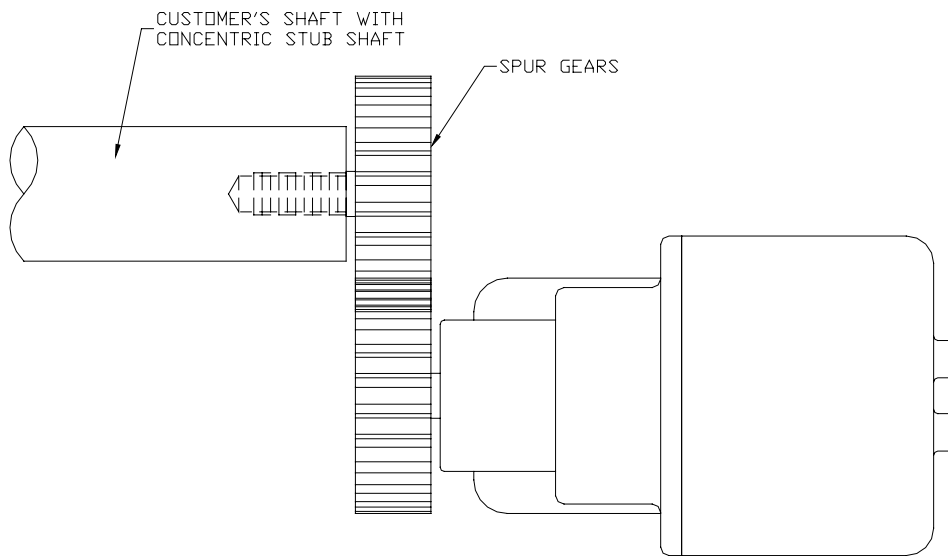

Figure 8: Offset mounting using belt / chain drive

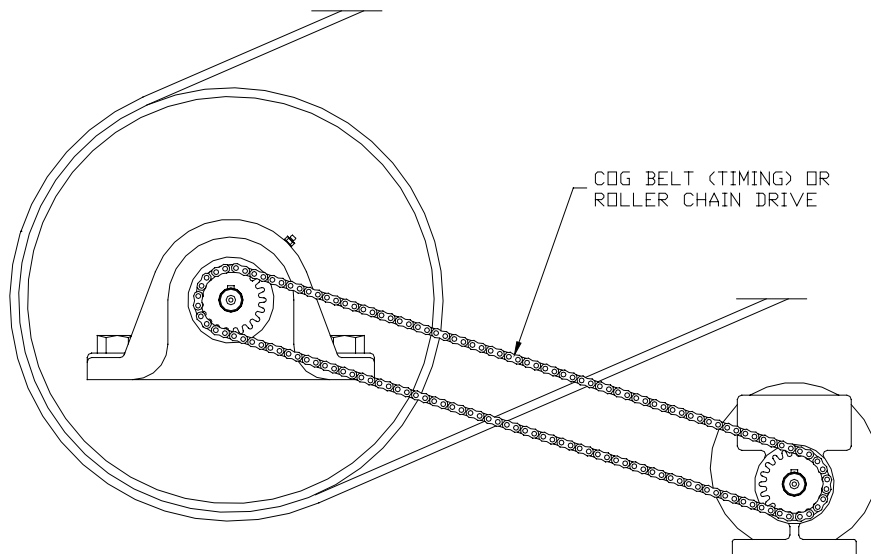
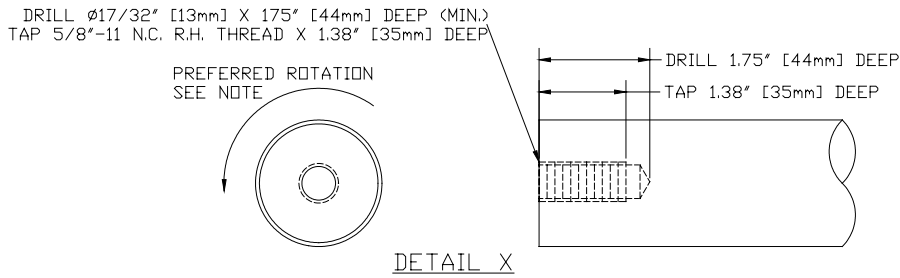

Figure 9:



NOTE: WHEN THREADED STUB SHAFT (PART NO. 303) IS USED, IT IS RECOMMENDED THAT THE LOCATION OF THE STUB BE IN THE END OF THE SHAFT THAT ROTATES COUNTER-CLOCKWISE. THIS ALLOWS THE THREADS TO CONTINUE BEING UNDER A CONSTANT FASTENING TORQUE WHILE THE SHAFT TURNS. IF THE ROTATION IS CLOCKWISE OR THE SHAFT IS FOR REVERSING TYPE SERVICE, MAKE SURE THE JAM NUT IS LOCKED TIGHT AGAINST THE SHAFT.

Figure 10: Typical mounting

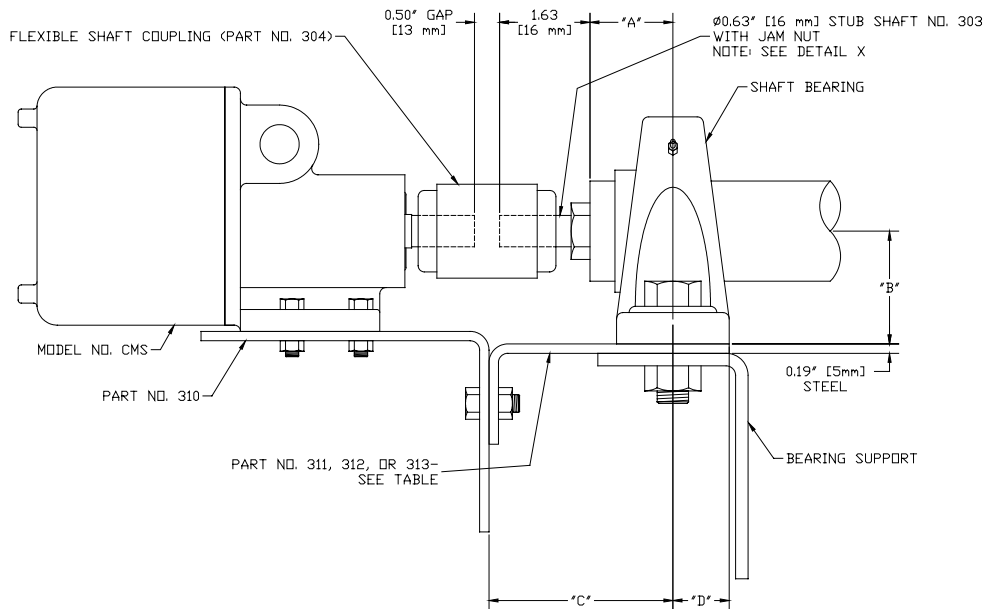
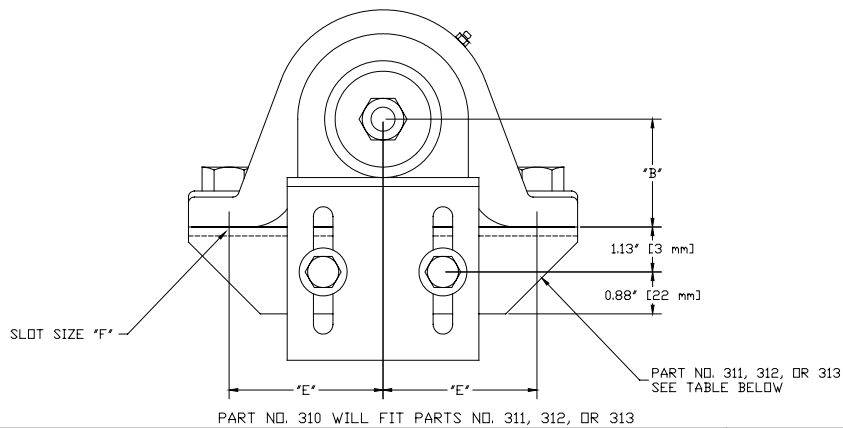

Figure 11: Bracket chart



ALL DIMS IN INCHES, EXCEPT DIMS IN [] ARE IN MILLIMETERS.							BEARING BRACKET & SHIM PLATE PART NO.
SHAFT DIA.	"A"	"B"	"C"	"D"	"E"	"F"	
1.44 [11]	1.25 TO 2.00 [32 TO 51]	1.88 TO 2.13 [48 TO 54]	3.13 [79]	1.13 [29]	5.38 [137]	0.56 W x 1.31 LG [14 W x 33 LG]	311
1.94 TO 2.44 [49 TO 62]	1.50 TO 2.56 [38 TO 65]	2.25 TO 3.00 [57 TO 76]	3.75 [95]	1.63 [41]	7.38 [187]	0.81 W x 1.94 LG [21 W x 49 LG]	312
2.94 TO 3.94 [75 TO 100]	3.00 TO 3.75 [76 TO 95]	3.13 TO 4.13 [79 TO 105]	4.50 [114]	2.19 [56]	9.63 [244]	1.06 W x 2.56 LG [27 W x 65 LG]	313