



SOLBERG

Integrated Liquid Separator / Vacuum Filter

LRS and SRS Series
For Vacuum Pumps



- *Protect Vacuum Pump*
- *Multi-Stage Filtration*
- *High Efficiency Separation*
- *Minimal Footprint*



Solberg Worldwide
www.solbergmfg.com
Discover the Possibilities



Integrated Liquid Separator / Vacuum Filter

LRS and SRS Series

The vacuum pump industry needed a liquid separator that would sustain vacuum, protect the pump, save space and provide high efficiency separation and filtration.

Solberg's LRS and SRS Series, Integrated Liquid Separator/ Vacuum Filter, provides the solution the market requires.

- Simplified vacuum package: Two functions combined into one (Liquid Separator and Air Filter)
- High efficiency separation and multi-stage filtration
- Pump protection from harmful liquids that destroy lubricating/seal oil
- Lower costs from unnecessary piping
- Ease of maintenance
- Prevents emulsification of oil in oil lubricated systems
- ATEX and PED certification (upon request)
- Configurable product to best fit the application

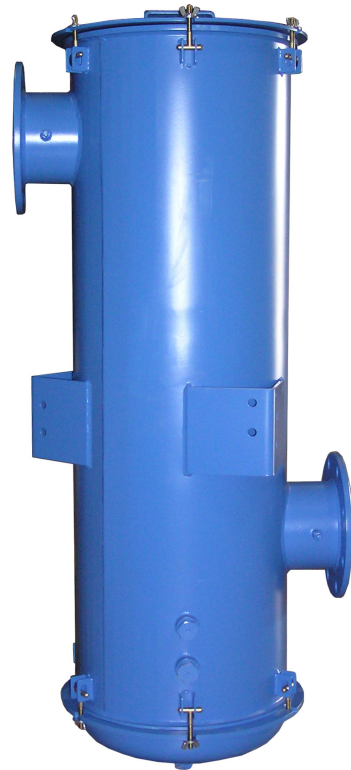

How the LRS/SRS Removes Liquid and Particulate

- ♦ The inlet air with potentially harmful liquids and particulate enters the highly efficient LRS/SRS and is separated by a baffling mechanism along with directional air flow changes.
 - ♦ The larger particles and liquid drop down to the large capacity lower chamber.
 - ♦ The lower chamber has significant liquid/slurry holding capacity and has a removable base for easy cleaning
 - ♦ The final stage has a replaceable element for fine filtration that is 99+% efficient before it reaches the vacuum pump.
- Note: The typical SRS style has a preseparator strainer element before the filter element for additional liquid/particulate removal.

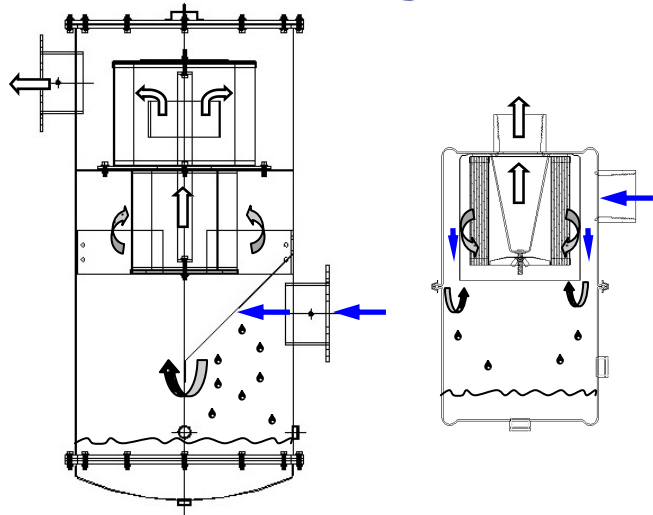

Multiple Configurations of the Solberg LRS/SRS Series



LRS Style



SRS Style
Custom



LRS Style
Aerosol Apps
Low Liquid Amounts



SRS Style
Customer Supplied
Electronics



SRS Style
ASME Code Housing

Note: Model offerings and design parameters may change without notice.

Solberg, Discover the Possibilities

How Solberg Solves Typical Marketplace Needs: High Grade Filtration and Vacuum Fluctuation

Solberg's Integrated Liquid Separator/Vacuum Filter solves these typical problems for the vacuum pump industry that traditional designs are unable to.

Typical Marketplace Need:

- Vacuum Fluctuates: The vacuum level could not be sustained in a 3 chamber liquid separator system because ambient air is introduced to the system when it replaces the liquid that is removed

Solution with Solberg's LRS/SRS Series:

- Sustained Vacuum Level: When the liquid and slurry is removed; air does not enter the LRS/SRS which allows vacuum to be maintained.

Typical Marketplace Need:

- High Grade Filtration Needed: The knock out pot style does not offer high efficiency filtration.

Solution with Solberg's LRS/SRS Series:

- Filter Integrated into Separator: The LRS/SRS has multiple stages of filtration in one compact unit.
 - Integrated baffle
 - Preseparator strainer (SRS Style Only)
 - 99+% efficient 5 micron (or better) filter element



ATEX and ASME Certified Filters (Upon Request)

In July 2003, the new ATEX Directive 94/9/EC (ATEX 95) was implemented Europe-wide to eliminate the possibility of explosions related to equipment used in potentially explosive gaseous or dusty environments

Solberg became one of the first to be certified to service those industries in need of compliance with this directive.

In addition to being able to provide the SRS series with ATEX certification. Solberg is able to provide ASME Coded filters as well.



ATEX and ASME
Certified Custom SRS



ASME

Note: Model offerings and design parameters may change without notice.

Solberg, Discover the Possibilities



Integrated Liquid Separator / Vacuum Filter

LRS and SRS Series

APPLICATIONS & EQUIPMENT

- The integrated liquid separator is primarily used in air process systems where liquids such as water or solvents need to be separated before the air reaches the air pump. Pump contamination leads to oil degradation, premature pump failures, and environmental problems.
- Designed for the air stream of a vacuum pump but can be used in most applications where liquid separation is needed.
- Food Packaging
- Pharmaceutical
- Chemical Processes
- Vacuum Pumps & Systems
- Metal Processing/Chip Processing
- Inquires Encouraged

FEATURES & SPECIFICATIONS

- 99% liquid removal efficiency
- Durable carbon steel construction with standard blue epoxy coating
- Integrated baffle mechanism
- Significant liquid holding capacity
- 1/4" taps on inlet/outlet ports standard for flange units
- 1" sight port for visual inspection
- 1" Drain port
- Max vacuum level: Typically 1.3×10^{-3} mbar
- Wide range of operation flows

OPTIONS

- ATEX certified housings
- ASME & PED rated housings
- Multiple configurations
- Stainless Steel - 1.4306 (304L) and 1.4435 (316L)
- Safety switch port for high liquid warning
- Electronics package (Customer Supplied)
- Custom media
- Vacuum gauges
- Support legs
- Custom connections
- Additional ports

LRS Series Style Specifications:

- "L" style configuration: side inlet, top outlet
- Multiple stage filtration:
 - Integrated Baffle System
 - Primary 99+% efficient filter element
- For aerosol apps, no additional knock out pot or separator needed
- Compact design

Reference Only Model No. with Polyester Element	Inlet & Outlet	Connection Style	Reference Only DIMENSIONS - inches					SCFM Nominal Rating	Approx Holding Cap. gal
			A	B	C	D	E		
LRS-19-075HC	3/4"	FPT	17	3/4	7 11/16	3	3/4	60	1.5
LRS-19-100HC	1"	FPT	17	3/4	7 11/16	3	3/4	85	1.5
LRS-19-125HC	1 1/4"	FPT	18	3/4	7 11/16	3	3/4	85	1.5
LRS-19-150HC	1 1/2"	FPT	18	3/4	7 11/16	3	3/4	100	1.5
LRS-237-200HC	2"	FPT	22 1/4	3/4	12	6	3/4	135	2.5
LRS-237-250C	2 1/2"	FPT	24 3/8	2 7/8	12	6	2 7/8	195	2.5
LRS-237-300C	3"	FPT	25 1/8	2 7/8	12	6	2 7/8	300	2.5
LRS-275-400F	4"	Flange	24 3/8	4	16	6	4	520	4.5
LRS-275-600F	6"	Flange	40 1/2	5	16	6	5	830	4.5

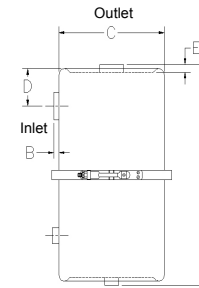

SRS Series Style Specifications:

- Offset connections: lower side inlet, upper side outlet
- Multiple stage filtration:
 - Integrated baffle system
 - Preseparator epoxy coated wire mesh strainer
 - Primary 99+% efficient filter element
- No additional knock out pot or separator needed
- Significant liquid and/or slurry holding capacity
- Removable base for easy access cleaning
- Brackets for support legs and nameplate
- Lifting lugs

Reference Only Model No.	Inlet & Outlet	Connection Style	Reference Only DIMENSIONS - inches					SCFM Nominal Rating	Approx Holding Cap. gal
			A	B	C	D	E		
SRS-377/274S-600F	6"	Flange	53 1/2	28	20 1/4	33 1/2	11 1/2	1275	20
SRS-385/376S-800F	8"	Flange	68 1/2	40	30 1/4	40	8	1800	45
SRS-385/376S-1000F	10"	Flange	68 1/2	39	30 1/4	40	11 1/8	1800	45
SRS-485/384S-1200F	12"	Flange	78 1/2	50	40 1/4	50	15	3000	80

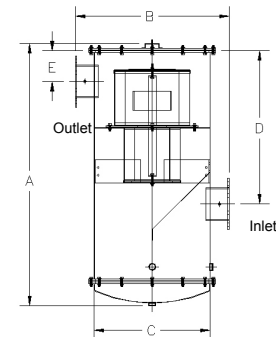

Dimension tolerance $\pm 1/4"$

Note: Model offerings and design parameters may change without notice.



Printed on Recycled Paper
Please Recycle

LRS-7303