

# Double Branch

## Ordering Information

- When ordering, specify material, gauge (if non-standard), dimensions A, B, C, D, end styles, and angle (standard 30°, optional 45°).
- $(A - C) \geq (C - B)$  and  $(C) \geq (D)$
- Use formula above to determine if a reducer is needed at C or D.

### 14 Gauge Branches:

- Any Branch with B, C or D end smaller than 8" will be hybrid. (Smaller section will be a lighter gauge.)

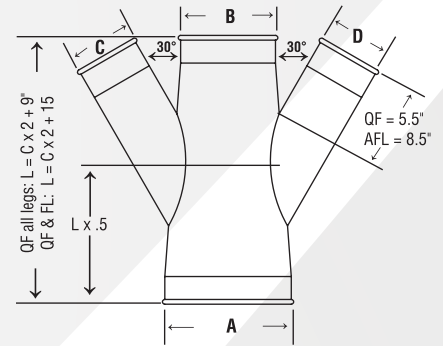

A Ø in.	Length in.	Weight Lbs
3		2.6
4		3.5
5		4.4
6		5.0
7		6.0
8		7.3
9		8.5
10	QF or Raw ends:	10.0
11		10.8
12	To manufacture, A - C must be greater to or equal to C - B and C must be greater than or equal to D.	12.3
13		13.2
14		15.0
15		17.4
16	Length = C X 2 + 9"	19.6
17		21.0
18		26.0
19		35.0
20		49.5
21		68.4
22		39.5
23		47.0
24		53.5
25		94.0
26		104.0
27		116.0
28		128.0
29	Angle Flange or Flat Flange ends:	140.5
30		153.0
31	To manufacture, A - C must be greater to or equal to C - B and C must be greater than or equal to D.	158.0
32		165.0
33		171.0
34		180.0
35	Length = C X 2 + 15"	184.0
36		188.0
37		195.0
38		203.5
39		212.0
40		223.0

## QF Material Options

Galv				SS			
Gauges	Size (inches)		Gauges	Size (inches)			
	Min. Ø	Max. Ø		Min. Ø	Max. Ø		
Standard	22	3	12	22	3	12	
	20	13	24	20	13	24	
Optional	18	4	24	18	8	24	
	16	8	24	16	8	24	
	14	8	24				

## Flanged Material Options

Galv				SS			
Gauges	Size (inches)		Gauges	Size (inches)			
	Min. Ø	Max. Ø		Min. Ø	Max. Ø		
Standard	22	3	12	22	3	12	
	20	13	24	20	13	24	
	18	26	30	18	26	30	
	16	32	40	16	32	40	
	14	42	50	14	42	50	
Optional	12	52	72	18	8	24	
	20	4	12	16	8	30	
	18	4	24				
	16	8	30				
	14	8	50				
	12	10	72				
	10	12	72				

**Please carefully note Nordfab Double Branch End Label designations (ABCD)**

### Construction

**Seam:** Longitudinal seam is lapped, spot welded, and caulked on standard gauges. 14ga and 12ga - Solid butt welds.

**Collars:** Located on the exterior side of each port and considered as air flow non-directional. Collars have a laser welded longitudinal seam. If airflow directional product is required, it must be stated on the PO and additional cost may be incurred. A raised lap seam and spot weld are used for attaching the collar to the body and no caulking is used. If caulking is required, additional cost may be incurred. 14ga and 12ga - Collars have a plasma welded longitudinal seam

### Optional End Styles

Standard QF end can be changed to Raw ID (RI), Raw OD (RO), No Fitting (NF), Hose Adapter (RF), Flat Flange (FFL), Angle Flange (AFL), or Van Stone (VS).