

TABLE OF CONTENTS

GENERAL SPECIFICATIONS	3
SAFETY SUMMARY	4
1.0 INTRODUCTION	5
2.0 APPLICATIONS	5
3.0 INSTALLATION	5
3.1 Location and Mounting	5
3.2 Input Power and Field Wiring	5
3.3 Grounding	6
4.0 FAIL-SAFE SELECTION	7
4.1 Description	7
4.2 Fail-Safe High	7
4.3 Fail-Safe Low	7
5.0 CALIBRATION	8
5.1 Calibration Verification	8
5.2 Calibration Procedure	8
5.3 Sensitivity Selection	8
6.0 EXTERNAL VIEW LED	9
7.0 TIME DELAY	9
8.0 WARRANTY AND CUSTOMER SERVICE	9
9.0 DISPOSAL	10
FIGURE 1.1	11
FIGURE 1.2	12
FIGURE 2.1	13
DECLARATION OF CONFORMITY	14



PROCAP I GENERAL SPECIFICATIONS

Supply:	24 TO 240 VAC or VDC
Load:	4VA
Ambient Temperature: (Electronics)	-20° F to +145° F (-28° C to +62° C)
Sensitivity:	1 picofarad
Enclosure:	PROCAP I Type 4X, 5, 9, & 12 (HAZ LOC CL II E, F, & G) PROCAP I X Type 4X, 5, 7, 9, & 12 (HAZ LOC CL I C&D; CL II E,F, & G)
 Fuse F1:	0.4A 250V Time Delay 5 X 20MM BinMaster P/N 328-0064
Relay Contact Rating:	DPDT contacts; 10 Amps 250 VAC maximum
Fail-Safe:	Switch selectable "High" or "Low" level modes.
Calibration:	Set when probe is uncovered: COARSE adjust; single turn potentiometer FINE adjust; single turn potentiometer
Status Indicator:	Internal LED indicates material in contact with probe. PROCAP I has an external LED also
Time Delay:	Adjustable up to 30 seconds
Probe Shield:	Automatically compensates for material buildup on the probe
Mounting:	1 1/4" or 3/4" NPT
Conduit Entries:	3/4" NPT

SAFETY SUMMARY

Review the following safety precautions to avoid injury and prevent damage to the equipment.

The product should be installed, commissioned, and maintained by qualified and authorized personnel only.

Install according to installation instructions and comply with all National and Local codes.

Use electrical wire that is sized and rated for the maximum voltage and current of the application.

Properly ground the enclosure to an adequate earth ground.

Observe all terminal and relay contact ratings as called out on the nameplate and in the installation manual.

Insure that the enclosure cover is in place and secured tightly during normal operation.

If this product is used in a manner not specified by the manufacturer the safety protection could be compromised.

Safety Terms and Symbols



WARNING: Warning statements identify conditions or practices that could result in injury or loss of life. Risk of electrical shock.



CAUTION: Caution statements identify conditions or practices that could result in damage to this product or other property.

9250257.fm Rev C



1.0 INTRODUCTION

The Bin-Master PROCAP I is a point level control used to detect the presence or absence of solids or liquids. The PROCAP I operates on the capacitance principle and incorporates a "Quick Set" feature to simplify calibration. The PROCAP I includes switch selectable Fail-Safe output contacts and "Probe Shield" technology for ignoring material build up.

Upon installation the PROCAP I is set up with the probe uncovered. The "Quick Set" feature allows simple setup and calibration of the unit to achieve low, medium, or high sensitivity settings. The PROCAP I has an adjustable time delay for monitoring covered or uncovered conditions.

2.0 APPLICATIONS

For applications in pressurized vessels up to 500 PSI, the PROCAP I should be mounted with the 3/4" stainless steel coupling.

Process temperatures for the various probes are:

1. Delrin Sleeved Stainless Steel:	250 Deg. F
2. Teflon Sleeved Stainless Steel:	500 Deg. F
3. Flush Mount (Polyethylene):	180 Deg. F
4. Flush Mount (Teflon):	450 Deg. F
5. Bare Stainless Steel:	250 Deg. F
6. Flexible Extension:	250 Deg. F

The Delrin or Teflon sleeved stainless steel probe should be used when mounting the PROCAP I in a highly corrosive atmosphere. Confirm that the sleeve material is rated for use in the corrosive nature of the application. Bare metal Stainless Steel probes are suitable for granular or liquid material that is not electrically conductive. For electrically conductive material, in some applications, a coated (insulated) probe may need be used for the unit to effectively sense the material. Contact BinMaster if there are any questions about which probe to use for a specific application.

3.0 INSTALLATION

3.1 Location and Mounting

The probe should be located out of the direct flow of material. The PROCAP I is designed to mount utilizing either a 1 1/4" NPT coupling or 3/4" NPT coupling. When the PROCAP I is used with the flush mount probe, the flush mount probe mounts directly to the vessel wall using a 7" diameter bolt circle. Refer to Figures 1.1 and 1.2 for illustrations on installation, mounting options, and different probe combinations.

3.2 Input Power and Field Wiring



The PROCAP I can be powered from either an AC or a DC power source with a voltage range from 24 up to 240 volts. The power source can be either grounded or ungrounded. If powered from a grounded source the grounded circuit conductor should be connected to the N terminal. In this way the ungrounded circuit conductor is fused on the circuit board. A disconnecting means should be provided to disconnect incoming power to this device. Field wiring should conform to all national and local electrical codes and any other agency or authority having jurisdiction over the installation. For power input, use wire that is sized and rated for the maximum voltage and current as per equipment ratings and has a temperature rating of at least 70 degrees C. For relay output, use wire that is sized and rated for the maximum voltage and current as per application, up to 250VAC 10A, and has a temperature rating of at least 70 degrees C. Installation shall be done by qualified personnel.

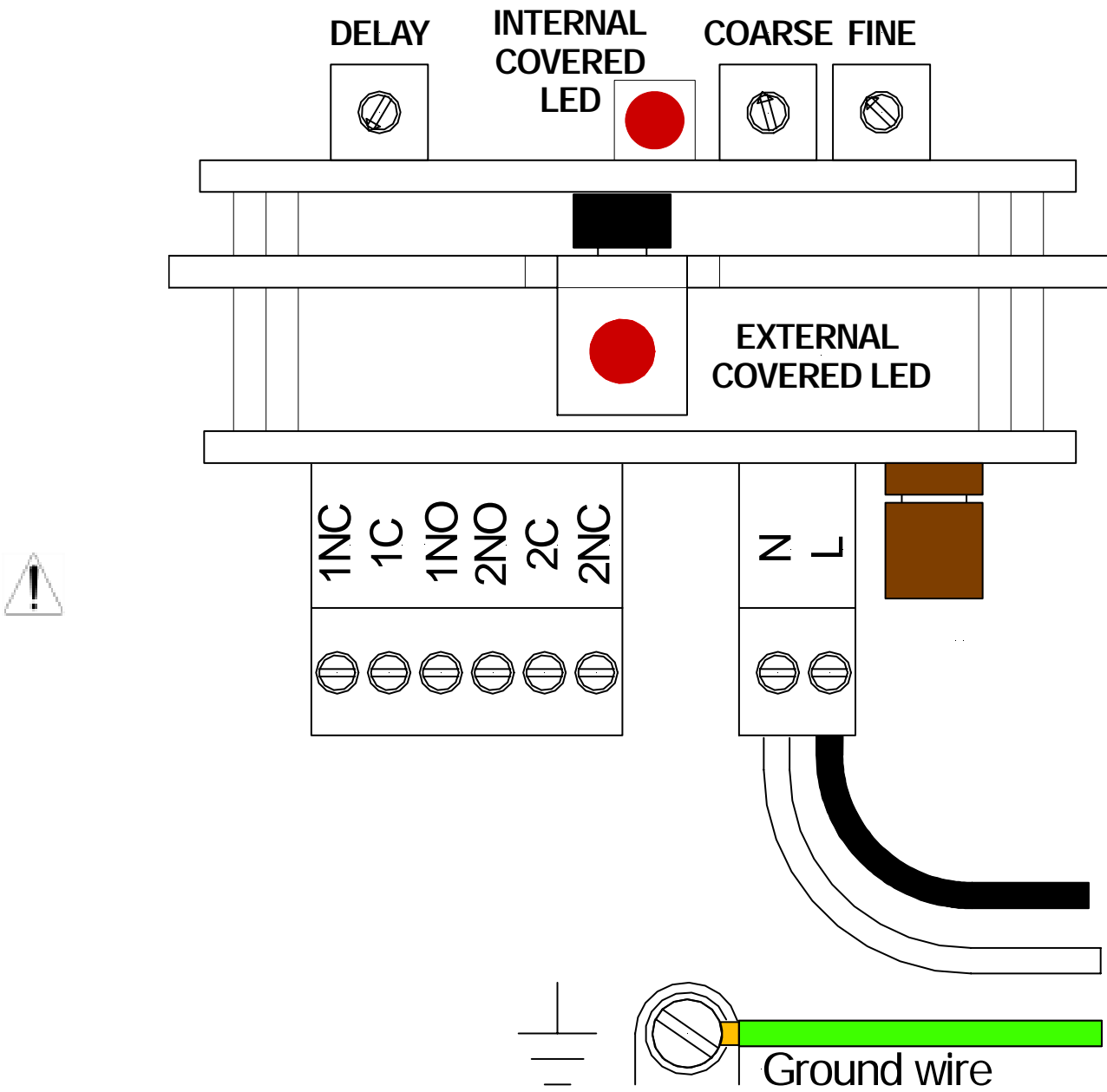

3.3 Grounding

 An equipment grounding connection (earth ground) **must** be supplied to the unit for safety and to insure proper operation of the unit. A green ground screw is provided in the enclosure for connection of an equipment grounding conductor as shown in the figure above. This unit uses earth ground as a reference for calibration and detecting a covered or uncovered condition. Therefore, the vessel in which the PROCAP I is mounted must be made of metal, or a suitable metal ground plate must be installed where the PROCAP I is mounted.

4.0 FAIL-SAFE SELECTION

4.1 Description

A Fail-Safe condition means that the relay contact positions are set up so that in the event of a power failure the relay will be de-energized and the contacts will indicate a condition that is deemed safe for the application. (Refer to FIGURE 2.1 for the location of the Fail-Safe selection switch.)

4.2 Fail-Safe High

Fail-Safe High means that the relay will be energized when the probe is uncovered and will de-energize when the probe is covered. In this mode, a power failure will cause the relay contacts to indicate that the probe is covered whether it is or not.

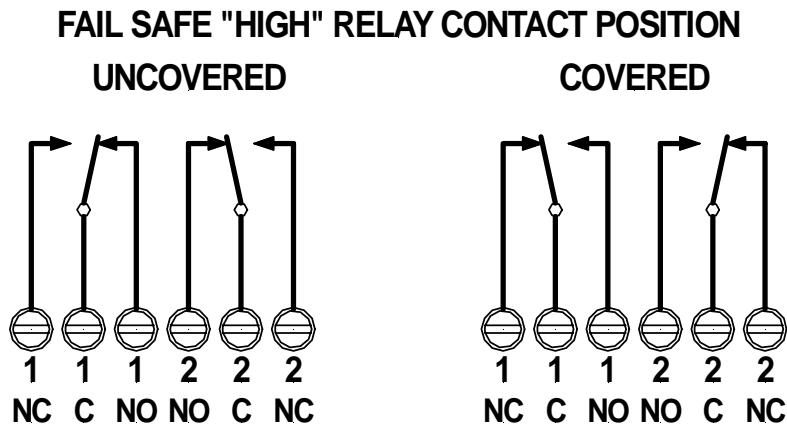

4.3 Fail-Safe Low

Fail-Safe Low means that the relay will be de-energized when the probe is uncovered and will energize when the probe is covered. In this mode, a power failure will cause the relay contacts to indicate that the probe is uncovered whether it is or not.

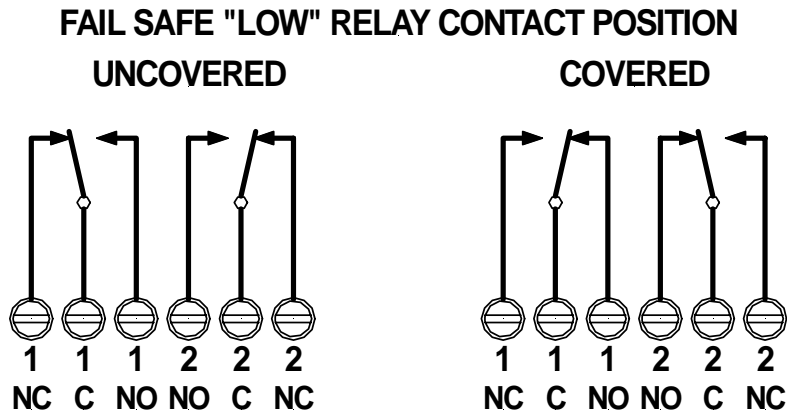

5.0 CALIBRATION

The PROCAP I Quick Set calibration uses two single turn potentiometers making calibration very simple. One potentiometer labeled COARSE is used to compensate for the capacitance of the empty vessel. The other potentiometer labeled FINE is used to set in the desired sensitivity. Refer to FIGURE 2.1 for the location of these potentiometers on the printed circuit board.

NOTE: Accurate calibration requires that the appropriate probe is attached to the PROCAP I and the unit installed in the vessel. The probe must be UNCOVERED and material well below it.

5.1 Calibration Verification

Following calibration adjustment, the sensitivity setting that you have selected should be checked by verifying that the PRO CAP II senses a covered probe condition with your material.

5.2 Calibration Procedure



WARNING: During Calibration, this unit will need to be energized. Care should be taken to not come in contact with any live voltage in the area around the terminal blocks and fuse!

CAUTION: The Calibration potentiometers are delicate electronic devices, do not use excessive force when adjusting.

1. Turn both the COARSE and FINE potentiometers fully counter clockwise (CCW). The internal COVERED indicator light should be OFF.
2. Turn the COARSE potentiometer slowly clockwise (CW) to the point where the COVERED indicator light just turns ON and stays on.
3. Turn the FINE potentiometer slowly clockwise (CW) until the COVERED indicator light just turns OFF. (If the COARSE potentiometer has been carefully adjusted, this should occur when the FINE potentiometer is between the 8 and 10 O'clock position.) Now continue to turn the FINE potentiometer clockwise (CW) to the desired sensitivity setting.

HIGH sensitivity:	1/16 turn
MEDIUM sensitivity:	1/8 turn
LOW sensitivity:	1/4 to 1/2 turn

NOTE: It may be convenient to think of the FINE potentiometer as a clock face and envision the distance between consecutive hour numbers. Turning the FINE potentiometer clockwise one hour position past the point at which the COVERED indicator just turns OFF would provide a high sensitivity setting. Two-hour positions past that point would provide a medium sensitivity setting..

5.3 Sensitivity Selection

Sensitivity Setting (typical)

HIGH sensitivity:
MEDIUM sensitivity:
LOW sensitivity:

Dielectric Constant of Material

4 or less
4 to 10
10 or higher

6.0 EXTERNAL VIEW LED

PROCAP I models include an external view LED. PROCAP I X models do not have an external view LED. This LED provides an externally visible status indication for the PROCAP I. When this LED is flashing, it indicates a normal **Uncovered** condition. When this LED is ON steady, it indicates a **Covered** condition. When this LED is OFF, it indicates a power failure or fault condition. This external LED is affected by any time delay set for the relay contacts.

7.0 TIME DELAY

The PROCAP I has an adjustable time delay of up to approximately 30 seconds. This is a time delay for the output to change states from an uncovered to a covered condition and from a covered to an uncovered condition. **This time delay affects the relay contacts and external LED only.** The internal Covered LED will immediately respond to a change in covered or uncovered condition regardless of the time delay setting.

Minimum time delay is when the DELAY potentiometer is set fully counter-clockwise. (Refer to FIGURE 2.1 for the location of the DELAY potentiometer.) Maximum time delay is with the DELAY potentiometer set fully clockwise.

A tool for adjusting the TIME DELAY potentiometer is provided inside the top cover of the PROCAP I. The cover has a convenient clip for storing the tool so it will always be available.

8.0 WARRANTY AND CUSTOMER SERVICE

8.1 Limited Warranty

The manufacturer warrants this equipment for two (2) years according to the following terms:

- 1.) This warranty extends to the original purchaser only and commences on the date of original purchase. The original purchaser must mail to the manufacturer the "Warranty Registration" card to confirm the equipment purchase. Failure to do so may void the warranty.
- 2.) The manufacturer will repair or replace any part of this equipment found to be defective, provided such part is delivered prepaid, to the factory. Manufacturer's obligation is limited to the cost of material and labor to repair or replace and does not include transportation expenses.
- 3.) This warranty shall not apply to any product that has, in our judgment, been tampered with, altered, subject to misuse, neglect or accident. In addition, the warranty does not extend to repairs made necessary by normal wear.
- 4.) This warranty is in lieu of all other warranties, expressed or implied.

**EXPLOSION HAZARD-SUBSTITUTION OF COMPONENTS MAY
IMPAIR INTRINSIC SAFETY**

8.2 Custom Service

Bin Master offers a toll-free Customer Service phone number **1-800-278-4241**. You may call the Customer Service Department for technical and application assistance Monday through Friday from 8:00AM to 5:00 PM Central Time. International customers call us at **(402) 434-9102** or reach us via fax at **(402) 434-9133**.

9.0 DISPOSAL

This product consists of materials that can be recycled by specialized recycling companies. It uses recyclable materials and the electronics is designed to be easily separated. Consult local authorities for proper disposal locations.

9250257.fm Rev C



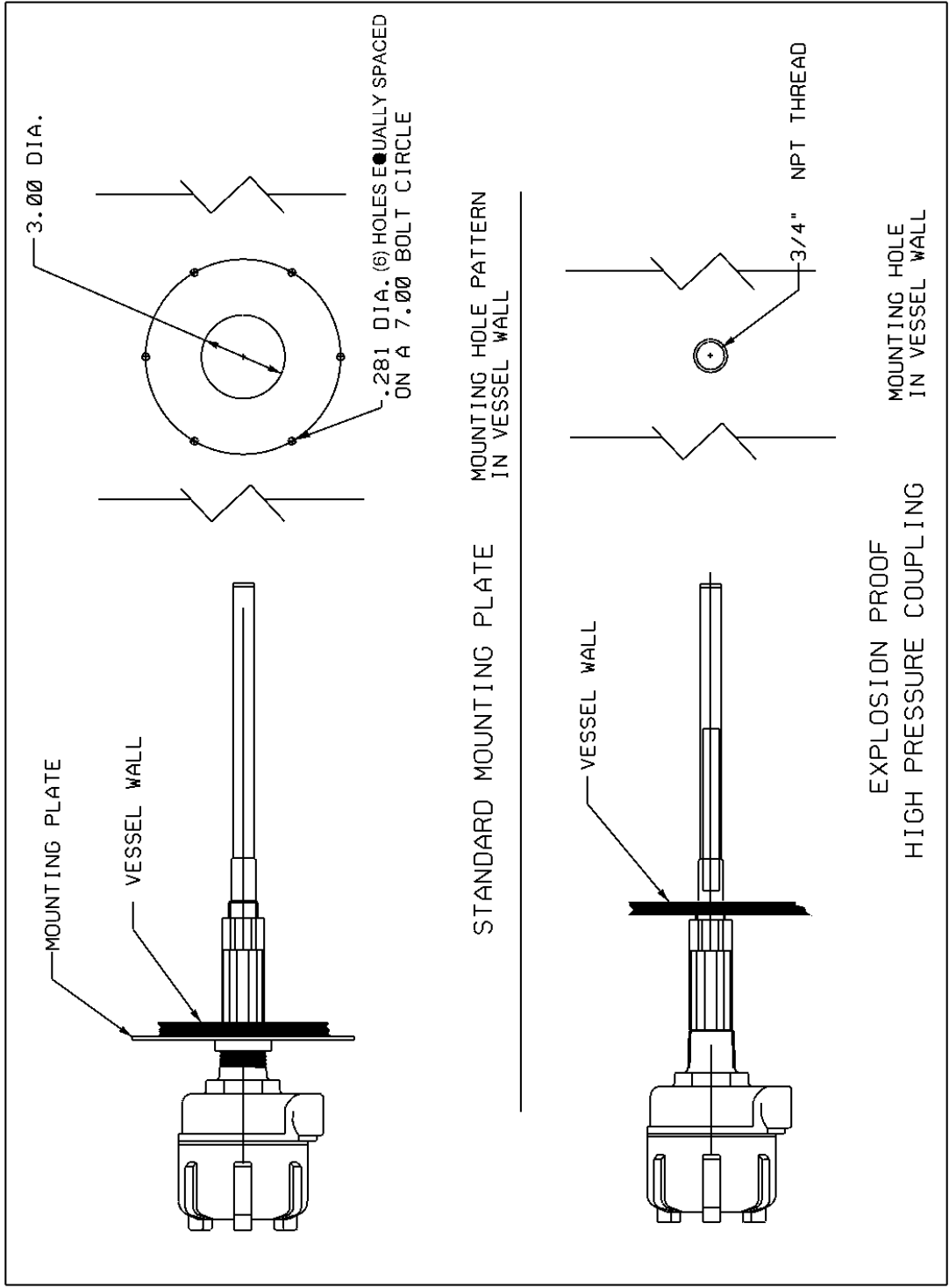

Figure 1.1

Declaration of Conformity

BinMaster Level Controls
7201 North 98th Street
Lincoln, NE 68507-9741
Phone: 402-434-9100, Fax: 402-434-9133

BinMaster declares that the PROCAP I and PROCAP IX level control devices as listed below comply with the following directives and harmonized standards. This product if installed, operated and maintained as described in this manual will provide a safe and reliable point level control device for bulk solid materials.

Low Voltage Directive 73/23/EEC
Standard IEC 61010-1:2001

Product: Capacitance point level control device.

Models: PROCAP I and PROCAP IX

All test reports and documentation are held and can be obtained from BinMaster.

Manufacturing Location: Lincoln, Nebraska, USA

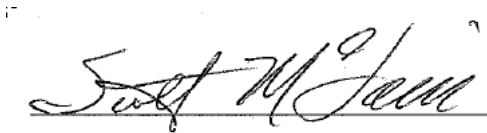

Scott McLain
President
3/25/2008

Mounting Instructions

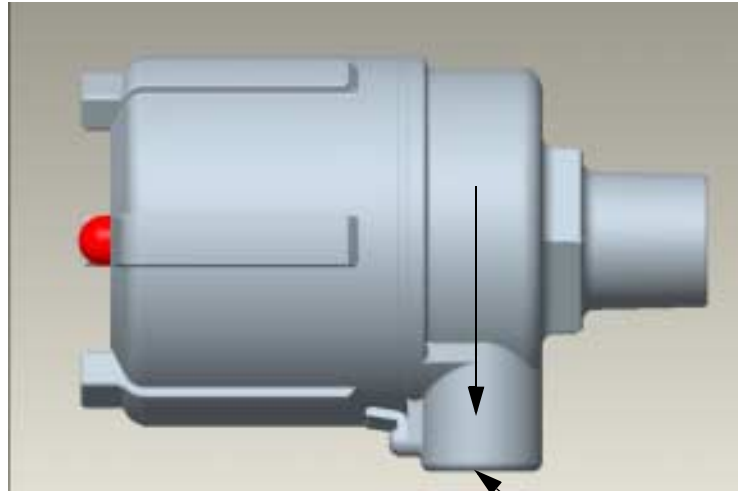

Always Mount Unit With
Conduit opening down

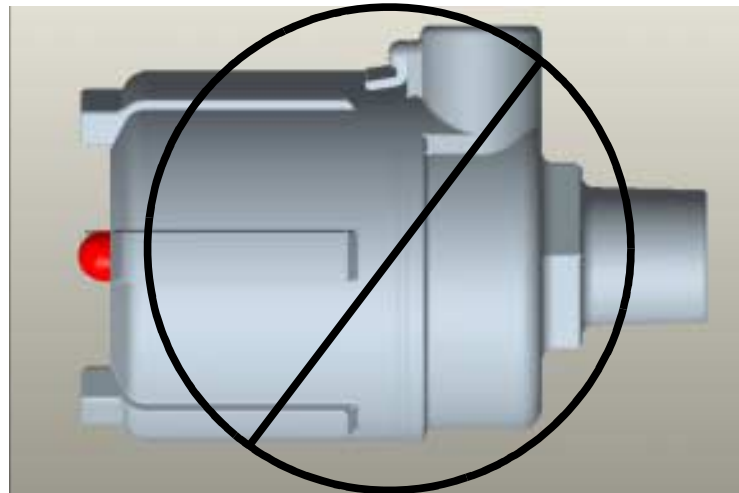

Conduit Seal

When installing this level indicator in environments where it is possible for moisture or moist air to enter the enclosure through the electrical conduit, the conduit opening should be sealed with a duct seal compound or putty appropriate for the purpose.

BINMASTER

9270255.fm

