

Declaration of Conformity

BinMaster Level Controls
7201 North 98th Street
Lincoln, NE 68507-9741
Phone: 402-434-9100, Fax: 402-434-9133

BinMaster declares that the PROCAP I and PROCAP IX level control devices as listed below comply with the following directives and harmonized standards. This product if installed, operated and maintained as described in this manual will provide a safe and reliable point level control device for bulk solid materials.

Low Voltage Directive 73/23/EEC
Standard IEC 61010-1:2001

Product: Capacitance point level control device.
Models: PROCAP I and PROCAP IX

All test reports and documentation are held and can be obtained from BinMaster.

Manufacturing Location: Lincoln, Nebraska, USA



Scott McLain
President
3/25/2008

Mounting Instructions

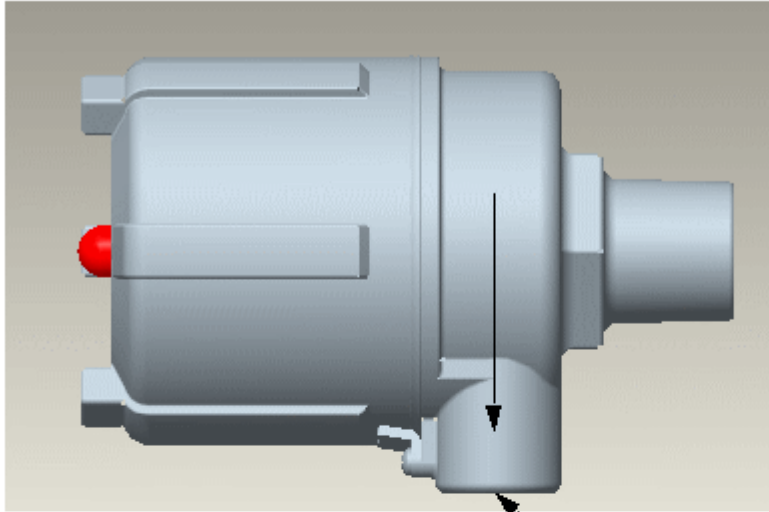

Always Mount Unit With
Conduit opening down

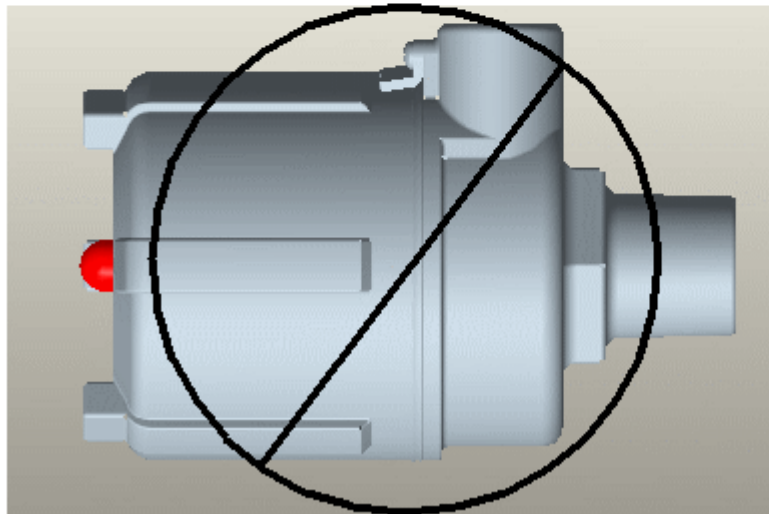

Conduit Seal

When installing this level indicator in environments where it is possible for moisture or moist air to enter the enclosure through the electrical conduit, the conduit opening should be sealed with a duct seal compound or putty appropriate for the purpose.

BINMASTER[®]