



OLI[®] Vibrator



AIR CUSHIONED PNEUMATIC LINEAR VIBRATORS

K-Type

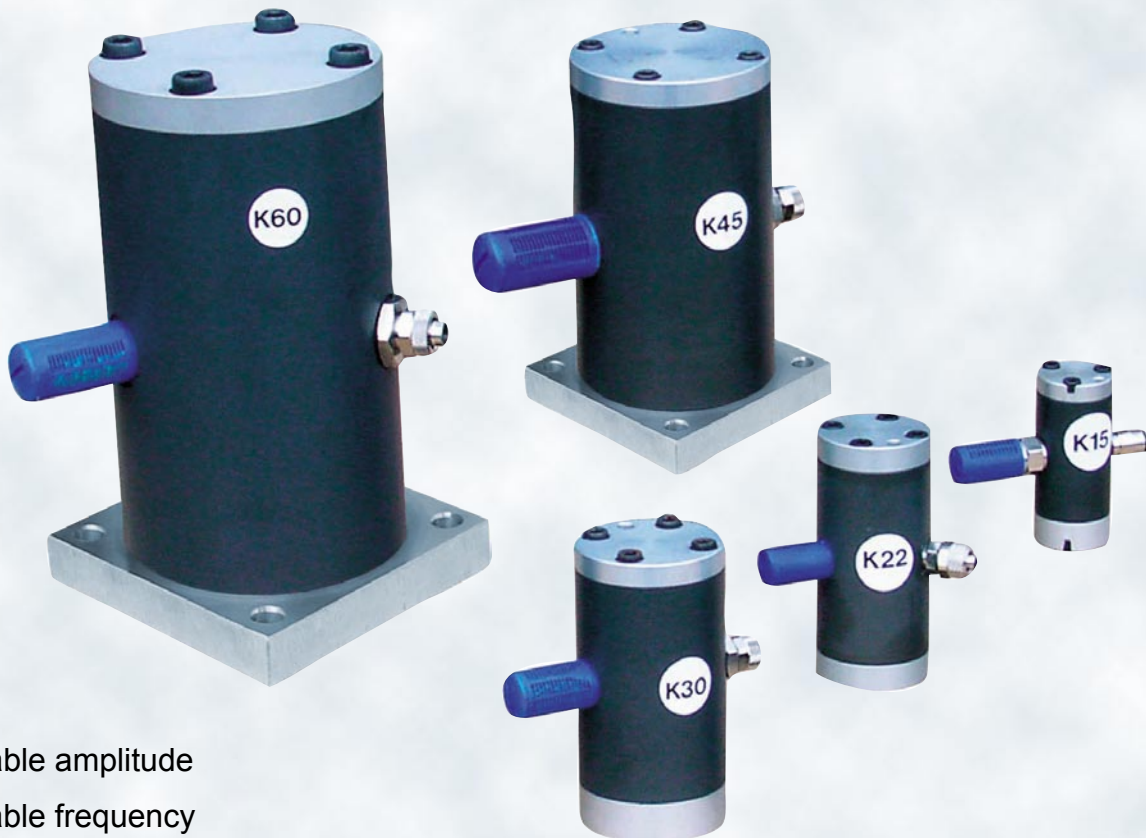

- ▶ Adjustable amplitude
- ▶ Adjustable frequency
- ▶ Starts in any position
- ▶ Low air consumption
- ▶ Minimum sound emission
- ▶ Excellent start / stop behaviour
- ▶ Explosion-proof, standard ATEX ExII3D
- ▶ Maintenance-free; oil-free operation possible
- ▶ Standard operation: from -20° C (-4° F) to 130° C (270° F)

Air Cushioned Pneumatic Linear Vibrators

K-Type

Description

The K-series Linear Piston Vibrators are particularly suitable for conveying, compacting and detaching of bulk solids due to perfectly linear vibrations. They reach optimum results in emptying of bins or as drives for vibrating conveyors or feeders.

Function

K-type Pneumatic Linear Vibrators are light and compact. Sinusoidal vibration is generated by a self-reversing piston which is freely floating on an air cushion. Frequency and amplitude can be continuously and independently adjusted. K-type Linear Vibrators may operate mounted in any position. Their start / stop behaviour is optimal.

Fig.1

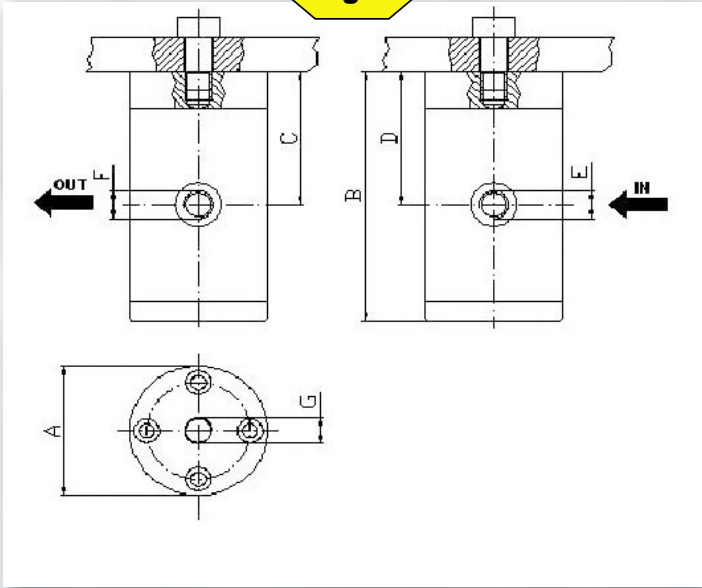
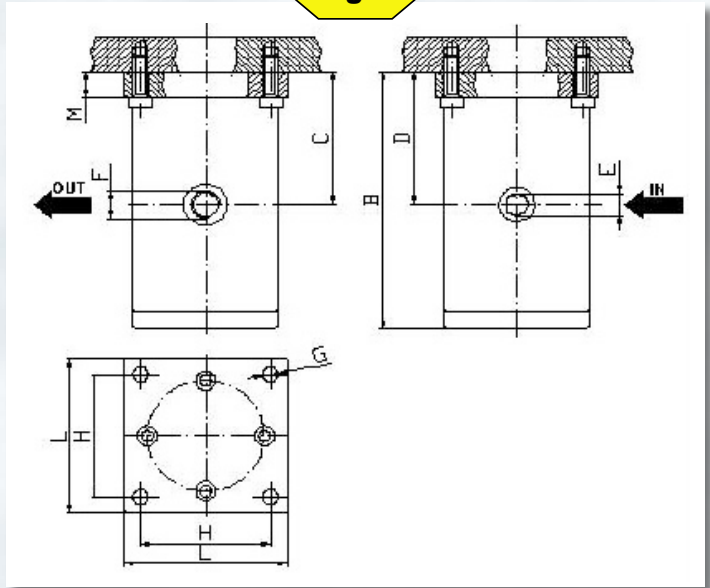

Fig.2



TYPE	RIF.	A		B		C		D		E	F	G		H		WEIGHT		L		M	
		FIG.	mm	in	mm	in	mm	in	mm			in	mm	in	mm	in	kg	lbs	mm	in	mm
K15	1	32	1.26	69	2.72	37	1.46	37	1.46	M5	1/8"	M8		/	/	0.17	0.38	/	/	/	/
K22	1	45	1.77	105	4.13	56	2.2	56	2.2	1/8"	1/8"	M10		/	/	0.5	1.11	/	/	/	/
K30	1	60	2.36	116	4.57	62	2.44	62	2.44	1/4"	1/4"	M12		/	/	1.03	2.27	/	/	/	/
K45	2	80	3.15	151	5.94	78	3.07	78	3.07	1/4"	3/8"	ø 8.5	0.33	72	2.83	2.86	6.3	90	3.54	15	0.59
K60	2	115	4.53	224	8.82	115	4.53	115	4.53	1/2"	1/2"	ø 13	0.51	102	4.02	7.7	17	130	5.12	20	0.79

TYPE	2 bar = 30 psi				3 bar = 43 psi				4 bar = 58 psi				6 bar = 87 psi			
	vibr.	Force		air cons.	vibr.	Force		air cons.	vibr.	Force		air cons.	vibr.	Force		air cons.
		kg	Lbs.			CFM	kg			Lbs.	CFM			kg	Lbs.	
K15	4500	6.17	13.6	0.1	5175	8.2	18.0	0.3	5625	9.7	21.3	0.5	6672	13.7	30.1	0.7
K 22	2850	19.84	43.6	0.2	3150	24.5	53.9	1.2	3450	29.3	64.5	1.4	4050	40.6	89.3	2.5
K 30	2475	30.6	67.3	0.8	2775	38.6	84.9	1.7	3075	47.4	104.3	3.9	3450	59.5	130.9	5.4
K 45	1800	85.1	187.2	1.9	2025	107.8	237.2	2.9	2250	133.2	293.0	4.4	2625	181.2	398.6	6.6
K 60	1200	145.5	320.1	1.8	1380	192.5	423.5	2.7	1500	227.5	500.5	4.4	1700	292	642.4	6.6

For activation a 3/2 way Electrovalve and filtered compressed air are required

N.B.: Rights reserved to modify technical specifications.



OLI Vibrator
4220 Steve Reynolds Blvd.
Bldg.2, Unit 10
Norcross, GA 30093 - USA

☎ (678) 380 - 6267
 ✉ (678) 380 - 6268
 E-mail sales@olivibrator.com
 Internet www.olivibrator.com